



**AKRAPOVIC SLIP-ON & SLIP-ON STREET LEGAL EXHAUST SYSTEM
for the
SUZUKI GSX-R 1000 (2005, 2006)**

Congratulations on purchasing an Akrapovic exhaust system. Please read these installation instructions carefully. If you have any trouble installing the system please contact your authorized dealer!

IMPORTANT INFORMATION

Exclusion of Certain Liability

1. The manufacturer, importer or dealer shall not be liable for any incidental damage including personal injury or any other damages caused by improper installation or operation of the Akrapovic exhaust system. When installing the Akrapovic exhaust system be careful that the exhaust system does not touch other parts sensitive to high temperature.
2. Akrapovic makes no representation or warranties with regard to damage caused by the improper installation, use and maintenance of the Akrapovic exhaust system. The warranty is limited to defects recognized by our technical department and to normal use, and excludes items subject to normal wear (gaskets and damping wool). The guarantee is void in case of accident, modification, improper or competition use.
3. Do not attempt to install the Akrapovic exhaust system on a motorcycle for which it was not made or tested by Akrapovic.
4. When the exhaust system gets very hot during operation, be careful not to burn yourself on the exhaust system or parts which are in direct contact with it, even when the motor is not running. Also protect other people, especially children, from the injuries mentioned above.
5. In some cases Akrapovic exhaust system kits contain chemical products (ceramic anti-seizing grease; bolt sealant). Handle with care, do not inhale or swallow. Avoid excessive contact with skin, eyes or mucous membranes. Keep out of reach of children.
6. Technical specifications of Akrapovic exhaust systems and related products subject to change without notice.

Trademarks

The Akrapovic Exhaust System Technology logo is a registered trademark of Akrapovic d.å.

Akrpovic website

Information about Akrapovic exhaust systems and related products is available on the Akrapovic website at:
<http://www.akrapovic-exhaust.com/>

Copyright

No part of the Akrapovic exhaust system or its documentation may be reproduced or distributed in any form or by any means without the prior written authorization of the Akrapovic company.





© Akrapovic d.å. All rights reserved.

Symbols

The following symbols are used throughout these installation instructions:



INSTALLATION INSTRUCTIONS

	BEFORE INSTALLING CHECK SCHEMATIC OF THE EXHAUST SYSTEM!
	IF ANY ITEMS IN THE AKRAPOVIC EXHAUST SYSTEM PACKAGE ARE MISSING PLEASE CONTACT YOUR AUTHORIZED DEALER. KEEP THE SCHEMATIC FOR FUTURE REFERENCE.
	THESE INSTALLATION INSTRUCTIONS MUST BE READ CAREFULLY IN ORDER TO ENSURE PROPER INSTALLATION AND OPERATION OF THE AKRAPOVIC EXHAUST SYSTEM.
	THE EXHAUST SYSTEM CAN BE EXTREMELY HOT. ALLOW THE MOTORCYCLE TO COOL DOWN BEFORE BEGINNING INSTALLATION.
	WE ADVISE YOU TO LEAVE INSTALLATION TO A QUALIFIED SERVICEMAN. IMPROPER INSTALLATION MAY RESULT IN A SHORTER LIFETIME OF THE EXHAUST SYSTEM AND/OR DAMAGE TO THE MOTORCYCLE.

REMOVAL OF STOCK EXHAUST SYSTEM

1. put the motorcycle on a side stand, we recommend a racing stand
2. unscrew the bolts and plastic fasteners from the side and inner part of the cowling (Figure 1, 2, 3, 4)
3. remove the inner part first (Figure 5) then complete cowling (Figure 6)
4. unscrew the bolts from the driver's right footpeg bracket (Figure 7)
5. remove the harness of the exhaust valve cables (Figure 8)
6. remove the cover of the exhaust valve (Figure 9, 10)
7. loosen and completely remove the cables from the exhaust valve (Figure 11, 12, 13, 14, 15)
8. unscrew the bolt from the exhaust valve bracket (Figure 16)
9. unscrew the bolt from the muffler chassis hanging bracket (Figure 17)
10. unscrew the bolt from the metal clamp at the muffler - link pipe joint and remove the muffler (Figure 18, 19)
11. remove the metal inner sleeve from the chassis hanging bracket of the exhaust valve (Figure 20, 21)
12. remove driver's seat and both side panels (Figure 22, 23, 24)
13. remove the bolts which fasten the fuel tank (Figure 25)
14. raise and firmly prop up the fuel tank (make sure it does not drop suddenly; you could damage the fuel tank) (Figure 26, 27)
15. completely remove the exhaust valve cables from the servo motor (from the control wheel for cable position) (Figure 28)
16. unscrew the bolt from the rear brake fluid container bracket and slightly remove the container (Figure 29)
17. unscrew the bolts from the servo motor chassis hanging bracket and slightly remove the servo motor (Figure 30, 31, 32)

INSTALLATION OF THE AKRAPOVIC SLIP-ON EXHAUST SYSTEM

installing the servo motor rotation limiter:

1. remove the stock control wheel for cable position (Figure 33, 34)
2. correctly position and install the Akrapovic servo motor rotation limiter; **WARNING: do not overtighten the bolt – you can damage the axle and rotation ability of the servo motor (Figure 35, 36, 37)**
3. reattach the servo motor (Figure 38, 39, 40)
4. reattach the rear brake fluid container (Figure 41)
5. completely remove the exhaust valve cables (Figure 42)
6. reattach the fuel tank, driver's seat and side panels (Figure 43, 44, 45, 46)

installing the independent link pipe:

1. coat the bolt and interior side of the metal clamp and additional metal ring with Akrapovic anti-seize lead-free copper paste (black tube) and correctly install the metal clamp onto the link pipe
2. correctly position and install the additional metal ring for attaching the spring onto the stock collector (Figure 47, 48)
3. **for titanium link pipe only:** coat the interior side of the input of the titanium link pipe with Akrapovic ceramic anti-seizing grease (white tube)
4. slide the Akrapovic link pipe onto the stock collector (Figure 49)
5. attach the spring (Figure 50)
6. make sure the link pipe is not touching the frame and other parts
7. reattach the drivers right footpeg bracket (Figure 51)

installing the muffler:

1. **for titanium link pipe only:** coat the interior side of the mufflers titanium inlet cap with Akrapovic ceramic anti-seizing grease (white tube)
2. position the muffler correctly and slide it onto the outlet side of the link pipe (Figure 52)
3. attach the springs at the Akrapovic muffler - link pipe joint (Figure 53)
4. correctly position the carbon-fiber clamp and slide it onto the muffler, bear in mind the **left offset** of the carbon-fiber clamp viewed from the rear **WARNING:** open the clamp to slightly wider than the diameter of the outer sleeve of the muffler – do not scrape it along the muffler outer sleeve! (Figure 54, schematic)
5. tighten the carbon-fiber clamp onto the stock chassis hanging bracket on the frame (Figure 55)
6. make sure the muffler is not touching other parts and that it is parallel to the longitudinal axis of the motorcycle
7. tighten the metal clamp at the Akrapovic link pipe – stock link pipe joint (Figure 56)
8. make sure the muffler is not touching other parts of the motorcycle

final installation:

1. clean grease spots:
 - a. muffler – titanium outer sleeve: use a soft cloth sprayed with a multi-purpose spray lubricant (WD-40 or equivalent)
 - b. muffler – carbon-fiber outer sleeve: use a soft dry cloth
 - c. stainless steel link pipe: use a soft cloth sprayed with a contact cleaner, then wipe with a soft dry cloth
 - d. titanium link pipe: use a soft cloth sprayed with a multi-purpose spray lubricant (WD-40 or equivalent)Cleaning will prevent spots from burning onto the surface. Do not use aggressive chemical cleaners, because they can damage the sticker.
2. reposition the complete cowling and tighten the bolts and plastic fasteners (Figure 57, 58, 59, 60)
3. position of the installed Akrapovic Slip-on system (Figure 61, 62)

Check the operation of the brakes and suspension. Make sure all the bolts are sufficiently tightened. In case the exhaust system touches the cowling or other parts repeat the adjustment of the exhaust system or contact your authorized dealer.

- | |
|---|
| ! IT IS NORMAL IF WHITE SMOKE COMES OUT OF THE MUFFLER ON FIRST OPERATION. |
| ! DO NOT STAND BEHIND THE MUFFLER ON FIRST OPERATION. |
| ! DO NOT USE AUTOMOTIVE WHEEL CLEANERS OR ANY CLEANING PRODUCTS WHICH CONTAIN ACIDIC ADDITIVES TO CLEAN AKRAPOVIC EXHAUST SYSTEMS. |

MAINTENANCE OF THE AKRAPOVIC EXHAUST SYSTEM

1. Clean the titanium muffler outer sleeve with a multi-purpose spray lubricant (WD-40 or equivalent) and carbon fiber outer sleeve with soft and dry cloth. Do not use aggressive chemical cleaners, because they can damage the sticker. A change in the color of the exhaust system is normal due to the high temperatures.
2. The wearing out of the muffler silencing material depends on the type of the motor and riding style. Contact your dealer/serviceman if visible changes appear on muffler's outer sleeve or the noise level is increased.
3. Periodically ensure that all the bolts and springs are sufficiently tight.

Photos:



Figure 1

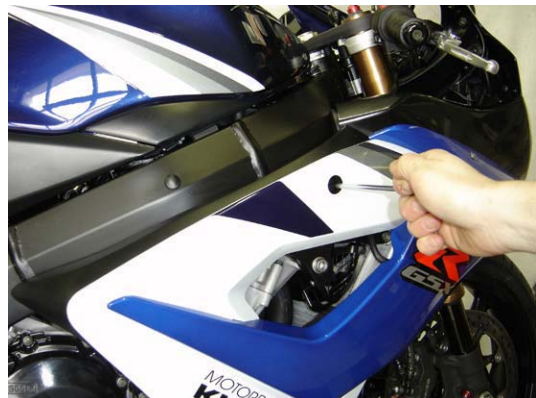

Figure 2



Figure 3



Figure 4



Figure 5

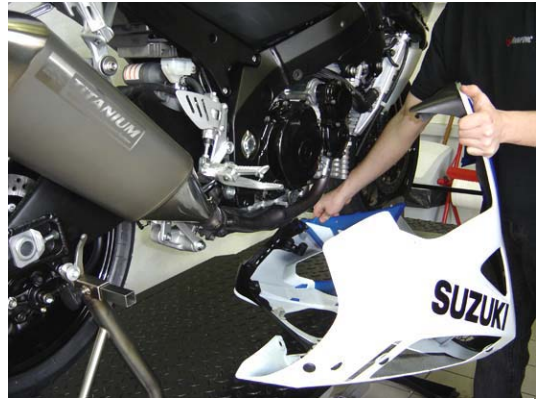

Figure 6



Figure 7

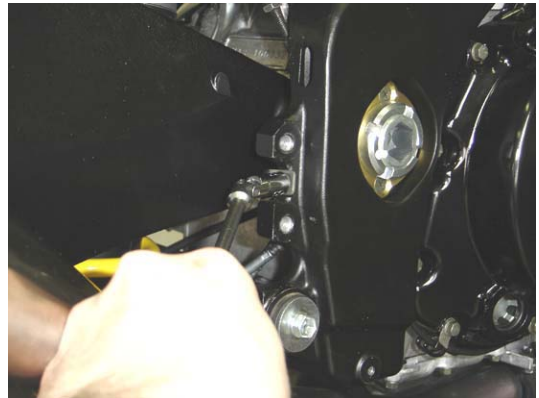

Figure 8



Figure 9



Figure 10

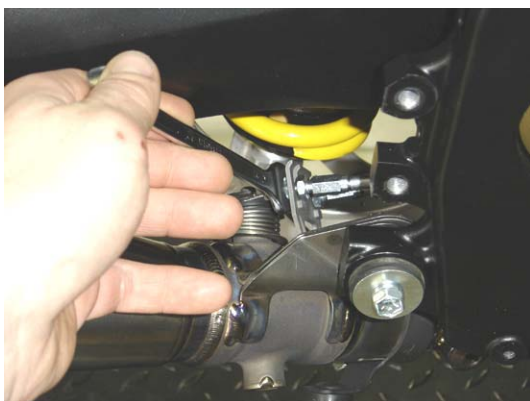

Figure 11



Figure 12



Figure 13



Figure 14



Figure 15

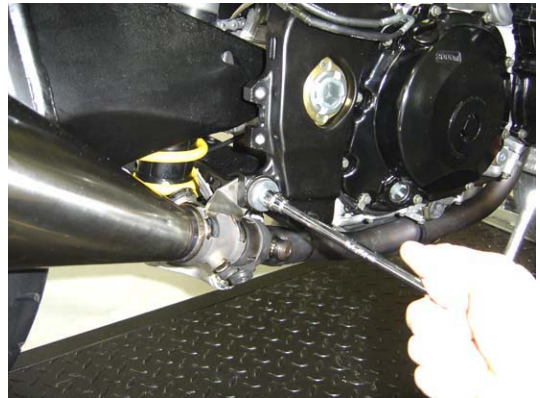

Figure 16



Figure 17



Figure 18



Figure 19



Figure 20



Figure 21



Figure 22



Figure 23



Figure 24



Figure 25



Figure 26



Figure 27



Figure 28



Figure 29

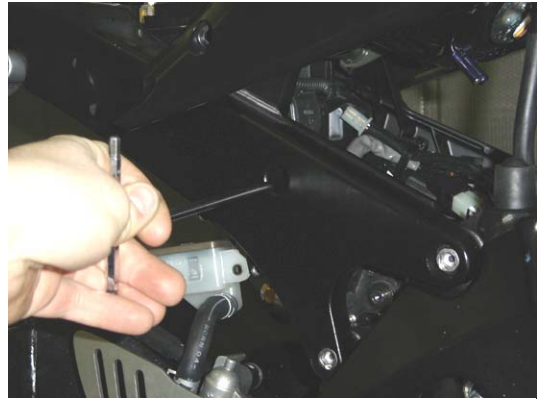

Figure 30

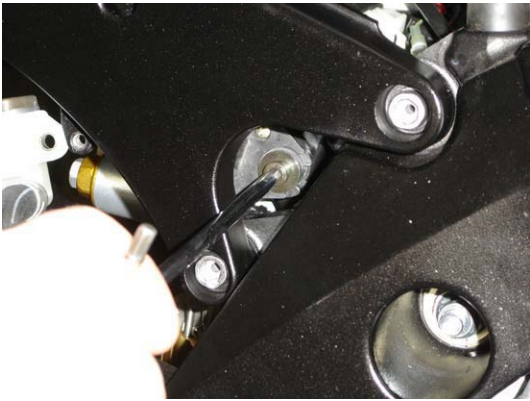

Figure 31

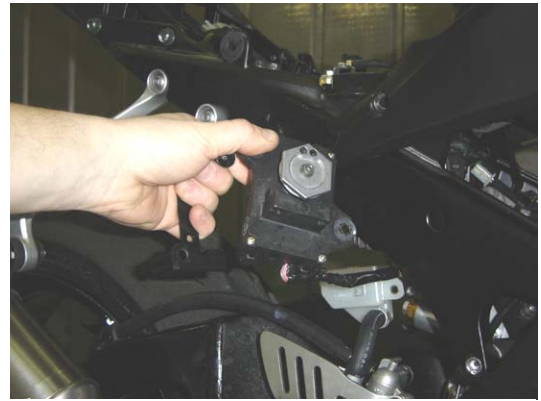

Figure 32

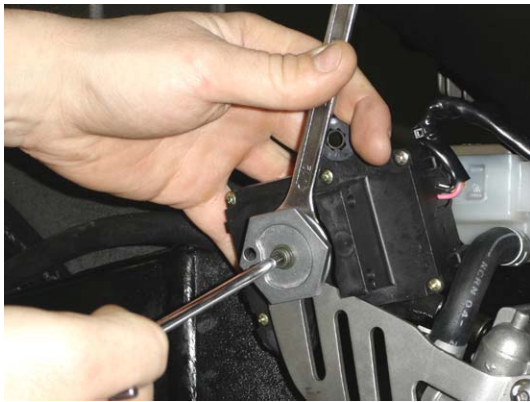

Figure 33



Figure 34



Figure 35



Figure 36



Figure 37

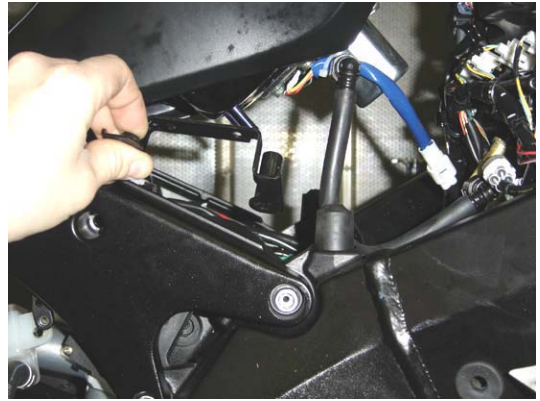

Figure 38

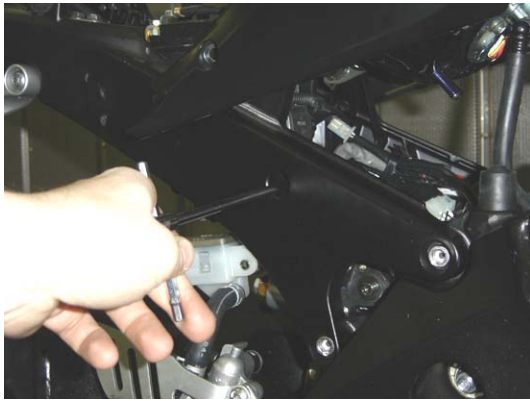

Figure 39

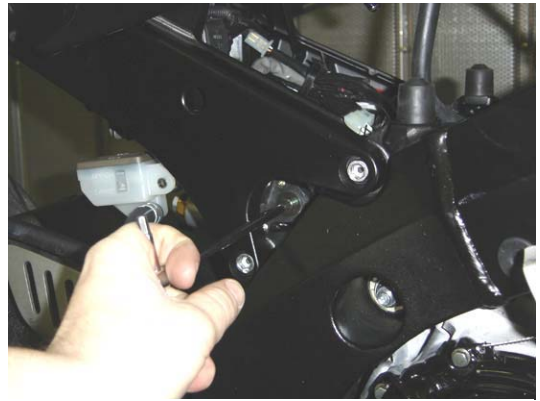

Figure 40

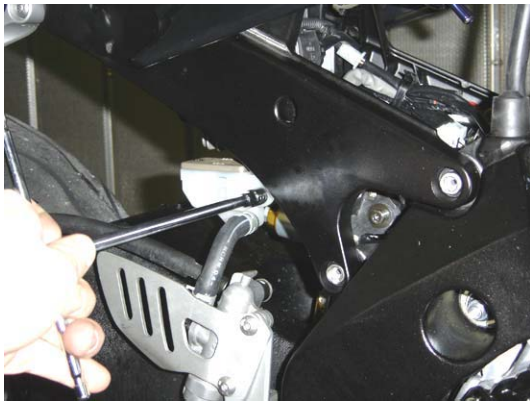

Figure 41



Figure 42



Figure 43



Figure 44



Figure 45



Figure 46



Figure 47

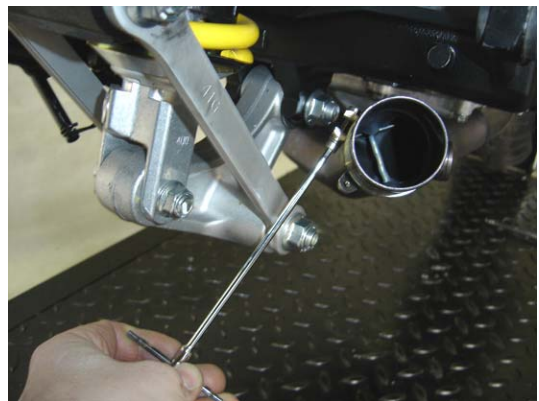

Figure 48



Figure 49



Figure 50

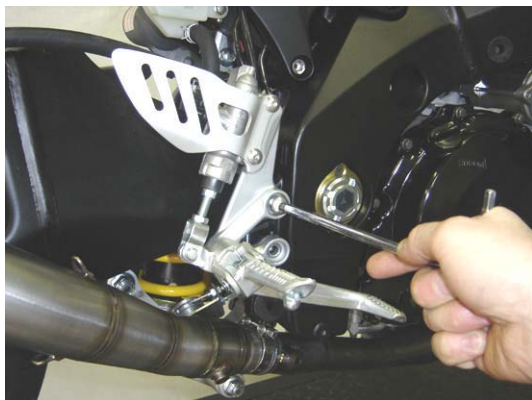

Figure 51

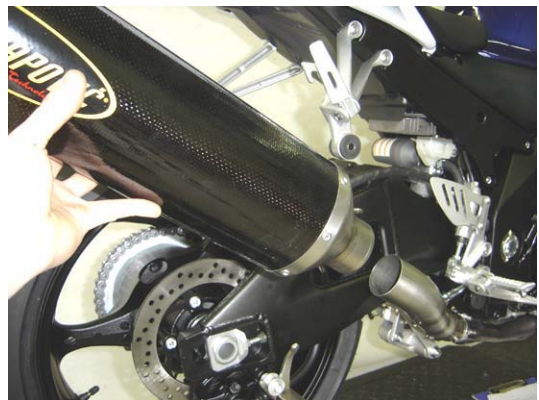

Figure 52



Figure 53



Figure 54



Figure 55



Figure 56



Figure 57



Figure 58



Figure 59



Figure 60

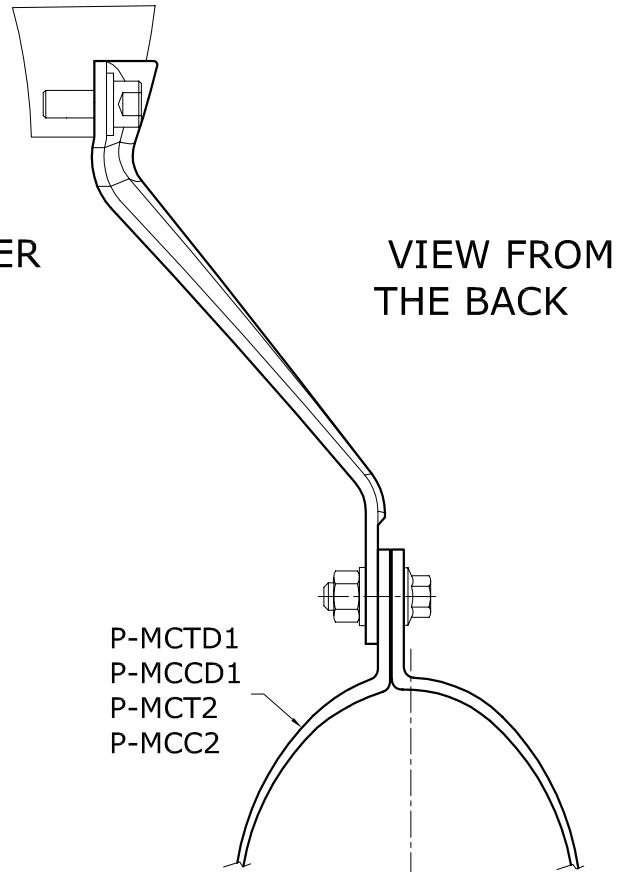
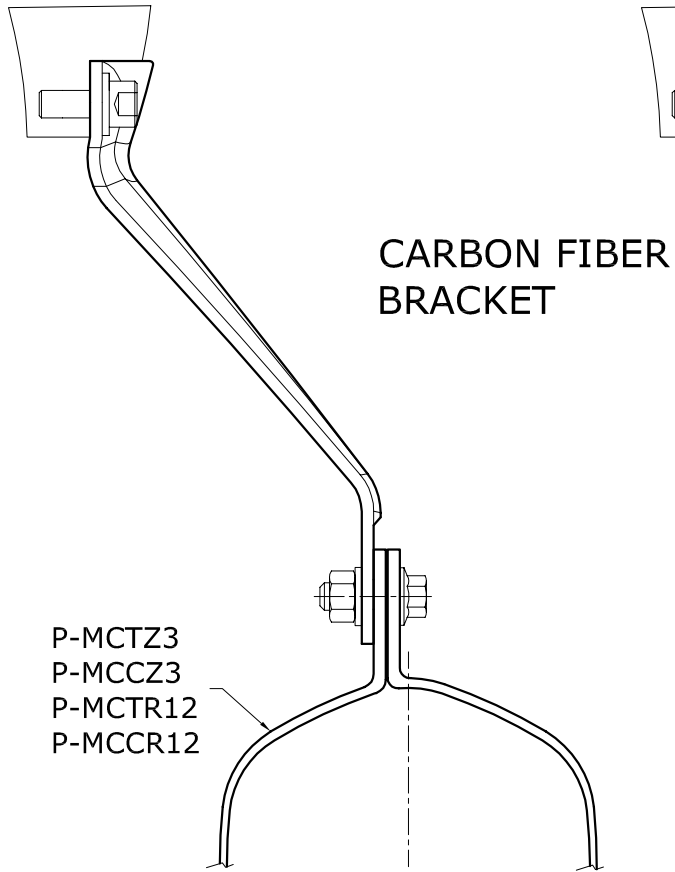

Figure 61



Figure 62

SUZUKI GSX-R 1000 K-05/06



ORIGINAL BRACKET WITH FOOTREST

VIEW FROM THE BACK

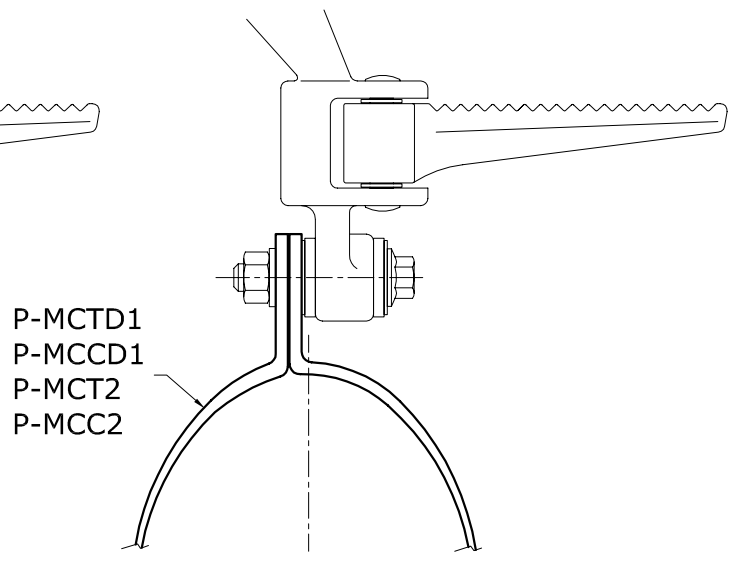
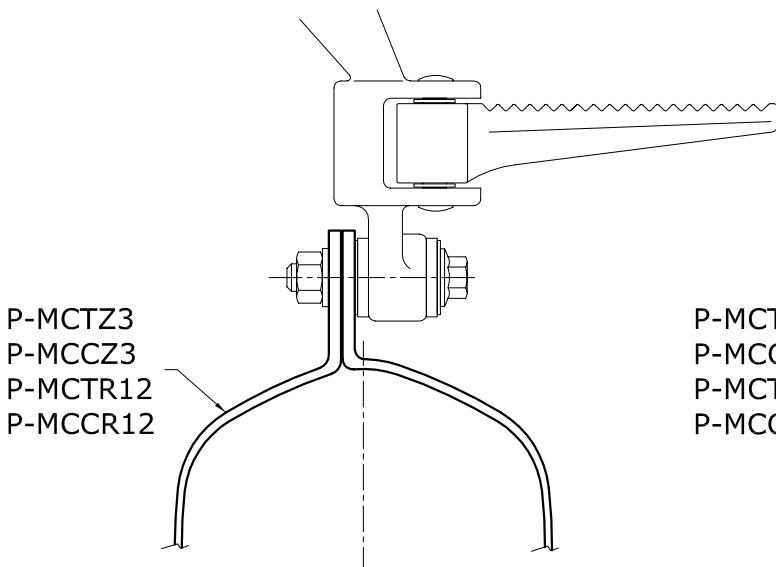

SUZUKI GSX-R 1000 Slip-on system, model year: 2005

Product code: 104080 (S-S10SO2-C)
104079 (S-S10SO2-T)

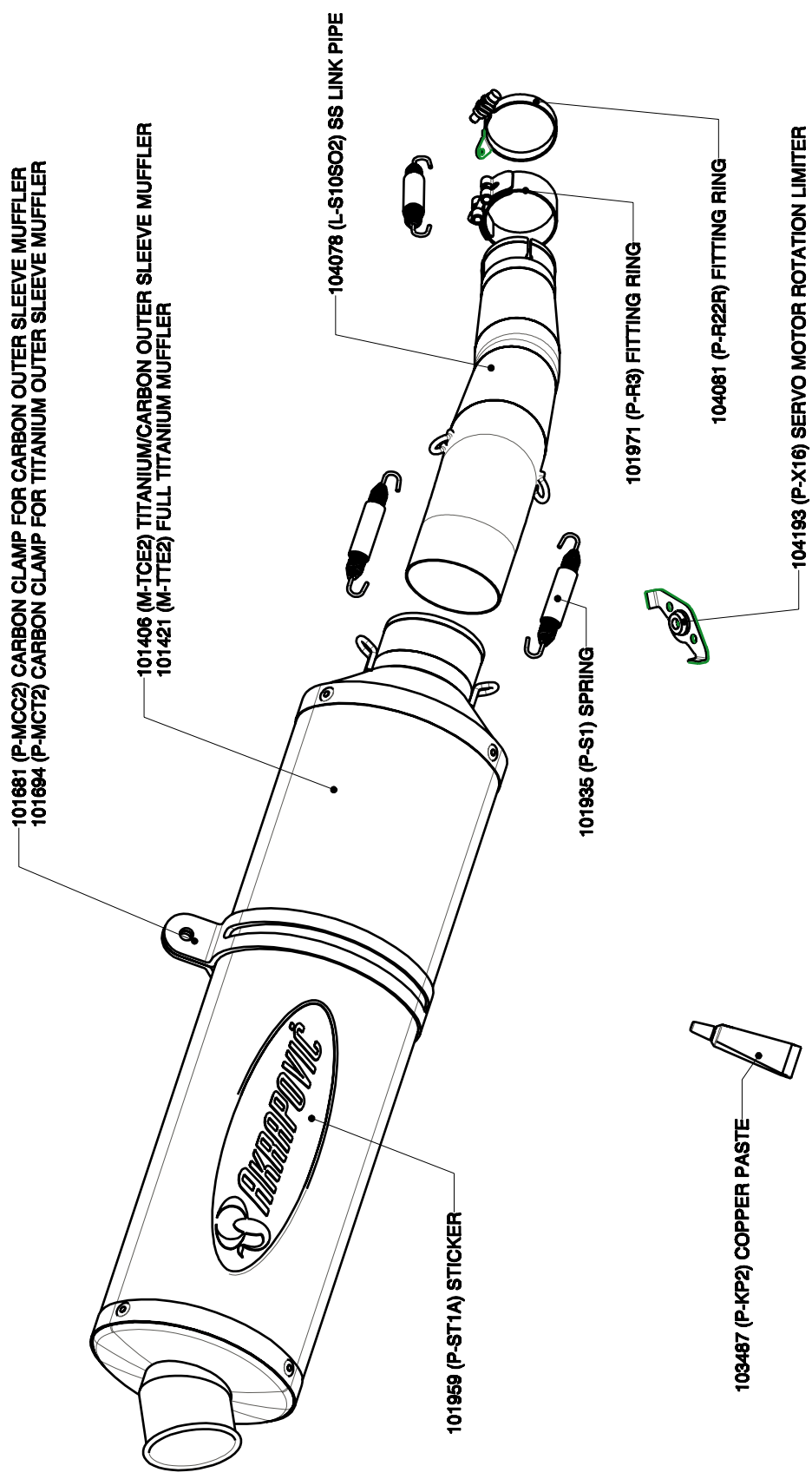

SUZUKI GSX-R 1000 Slip-on system, model year: 2005

Product code: 104239 (S-S10SO2T-C)
104240 (S-S10SO2T-T)

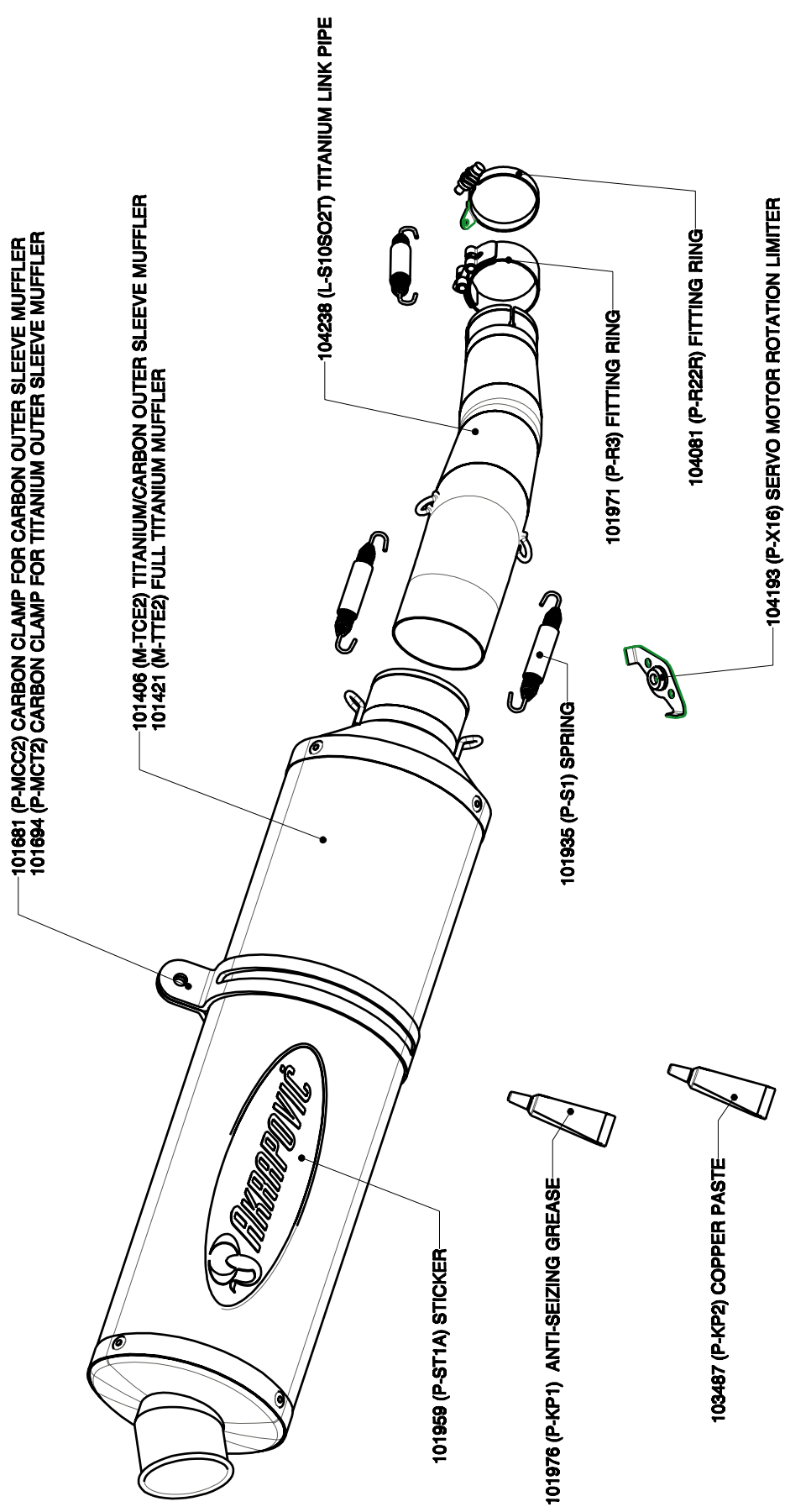

SUZUKI GSX-R 1000 Homologated/Slip-on system, model year: 2005

**Product code: 104241 (S-S10SO2-HC)
104242 (S-S10SO2-HT)**

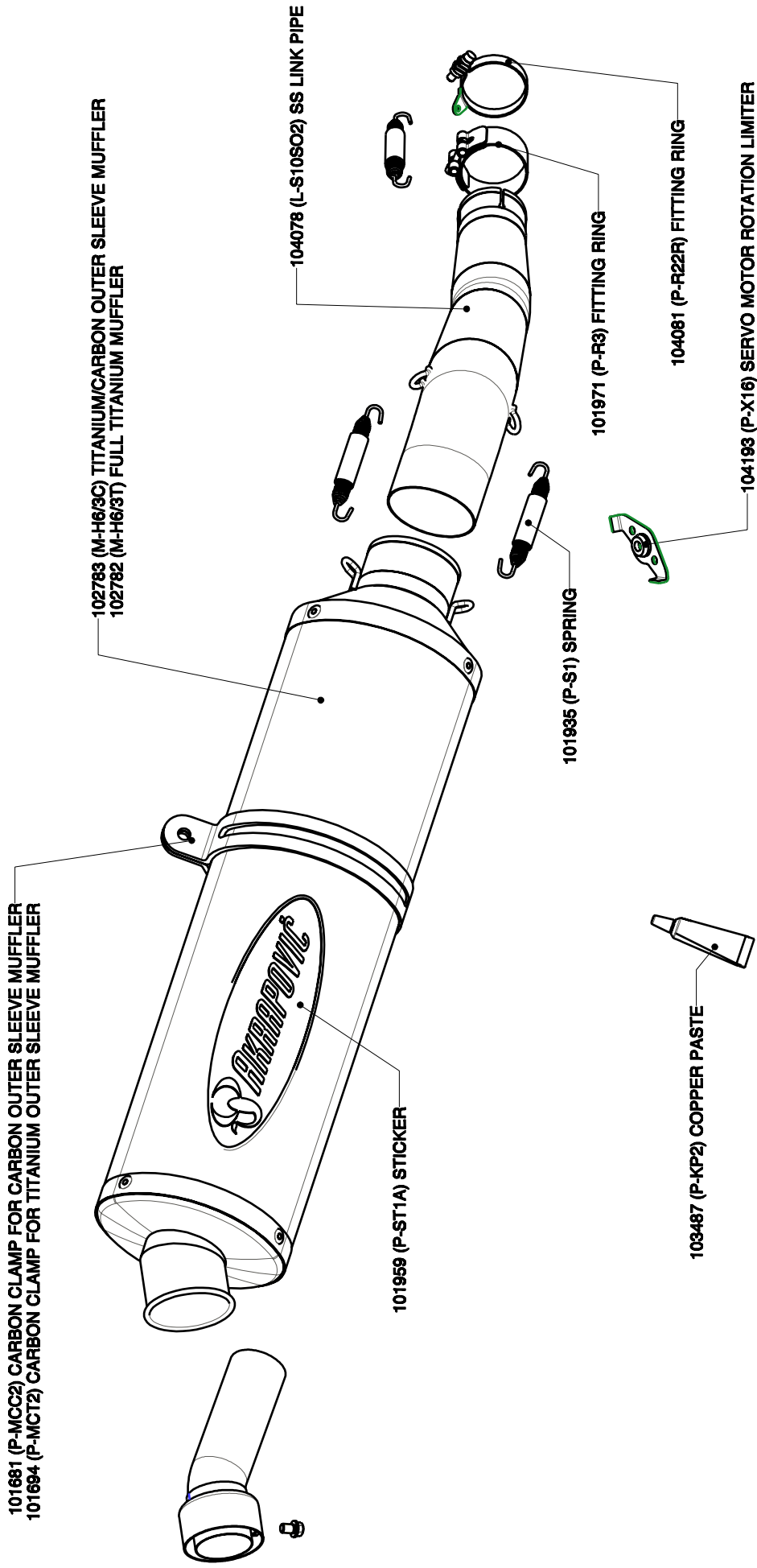

SUZUKI GSX-R 1000 Homologated/Slip-on system, model year: 2005

Product code: 104243 (S-S10SO2T-HC)
104244 (S-S10SO2T-HT)

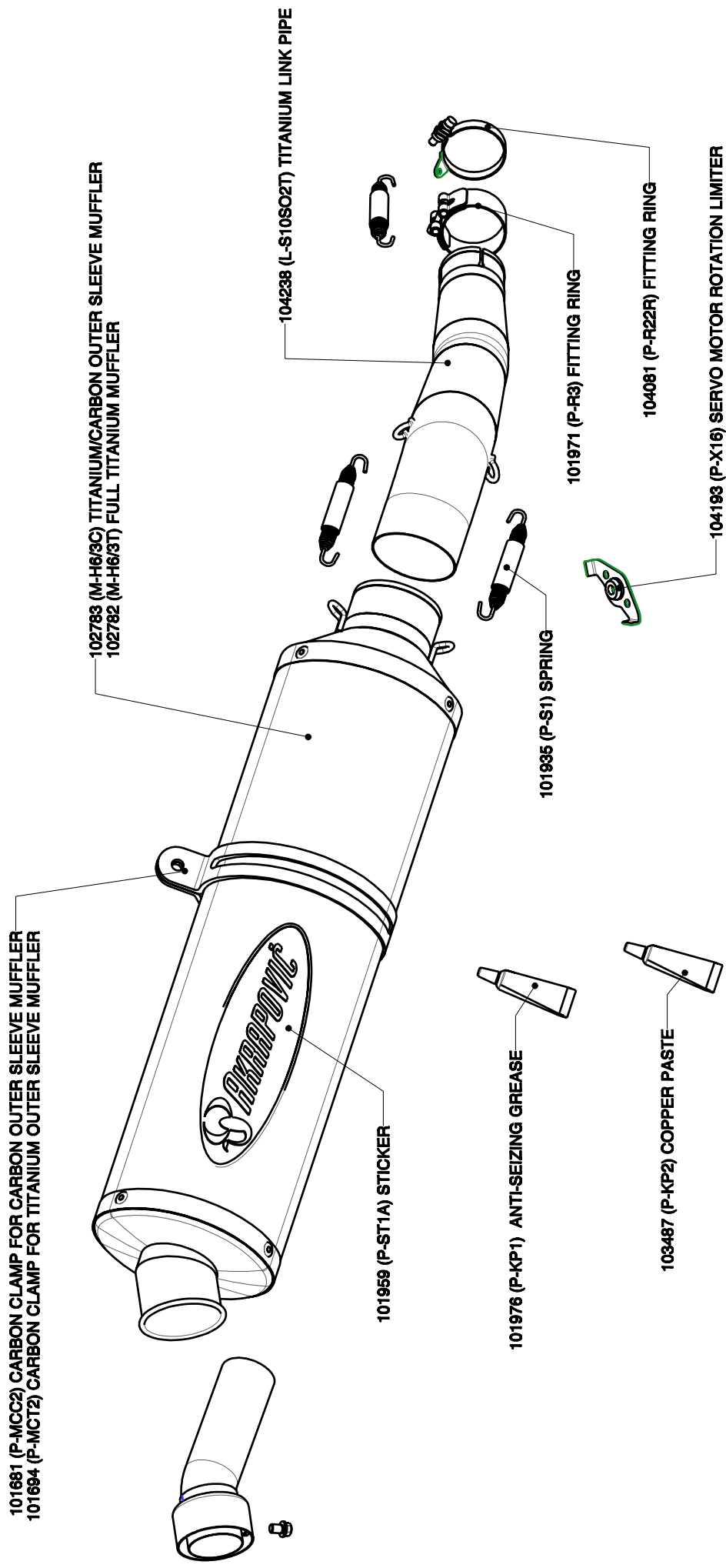

SUZUKI GSX-R 1000 Slip-on system, model year: 2005-2006

**Product code: 105454 (S-S10SO2-ZT)
105455 (S-S10SO2-ZC)**

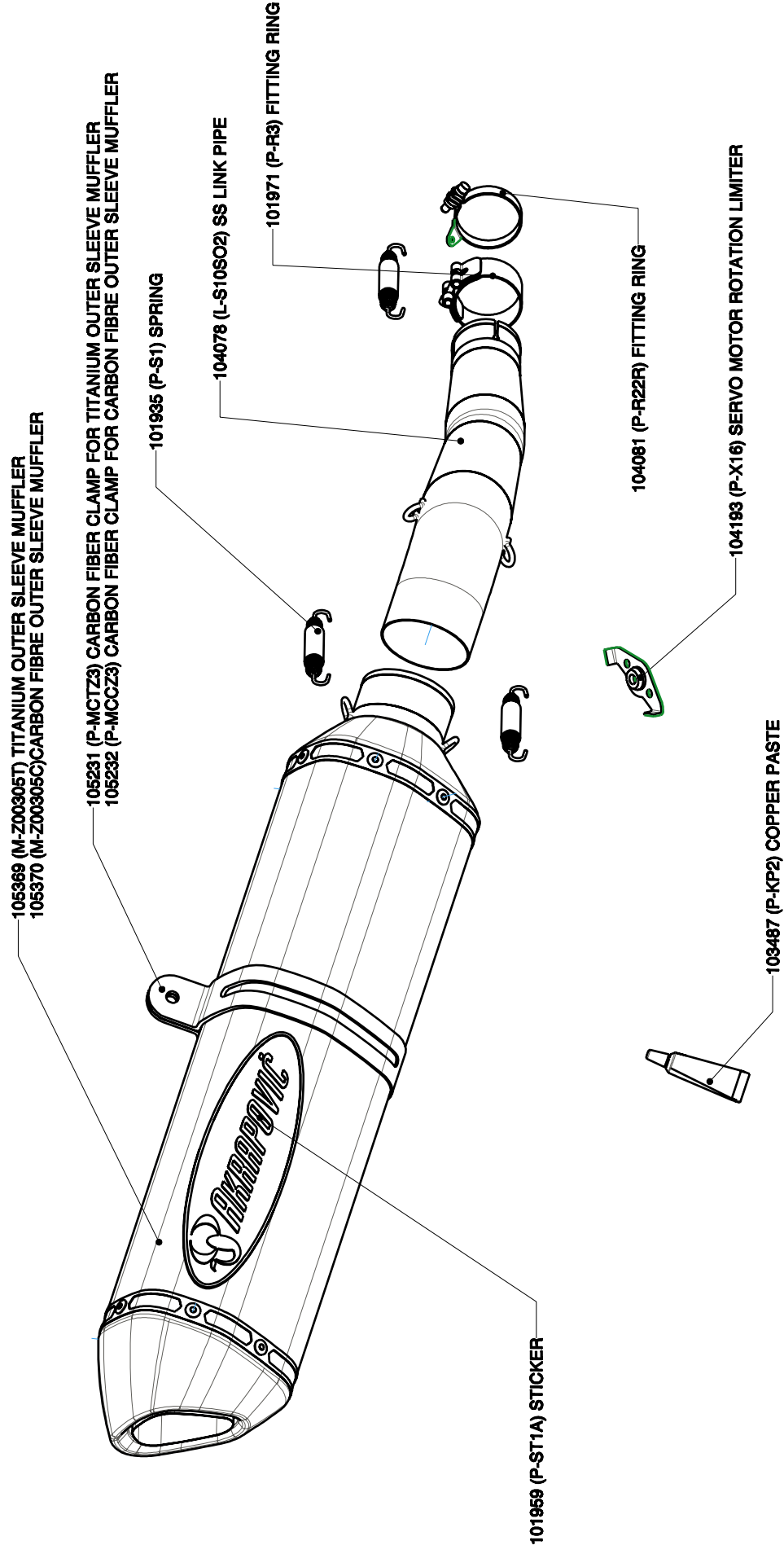

SUZUKI GSX-R 1000 Slip-on system, model year: 2005-2006

**Product code: 105452 (S-S10SO2T-ZT)
105453 (S-S10SO2T-ZC)**

105369 (M-Z00305T) TITANIUM OUTER SLEEVE MUFFLER
105370 (M-Z00305C) CARBON FIBRE OUTER SLEEVE MUFFLER

105231 (P-MCTZ3) CARBON FIBER CLAMP FOR TITANIUM OUTER SLEEVE MUFFLER
105232 (P-MCCZ3) CARBON FIBER CLAMP FOR CARBON FIBRE OUTER SLEEVE MUFFLER

101935 (P-S1) SPRING

104238 (L-S10SO2T) TITANIUM LINK PIPE

101971 (P-R3) FITTING RING

104081 (P-R22R) FITTING RING

104193 (P-X16) SERVO MOTOR ROTATION LIMITER

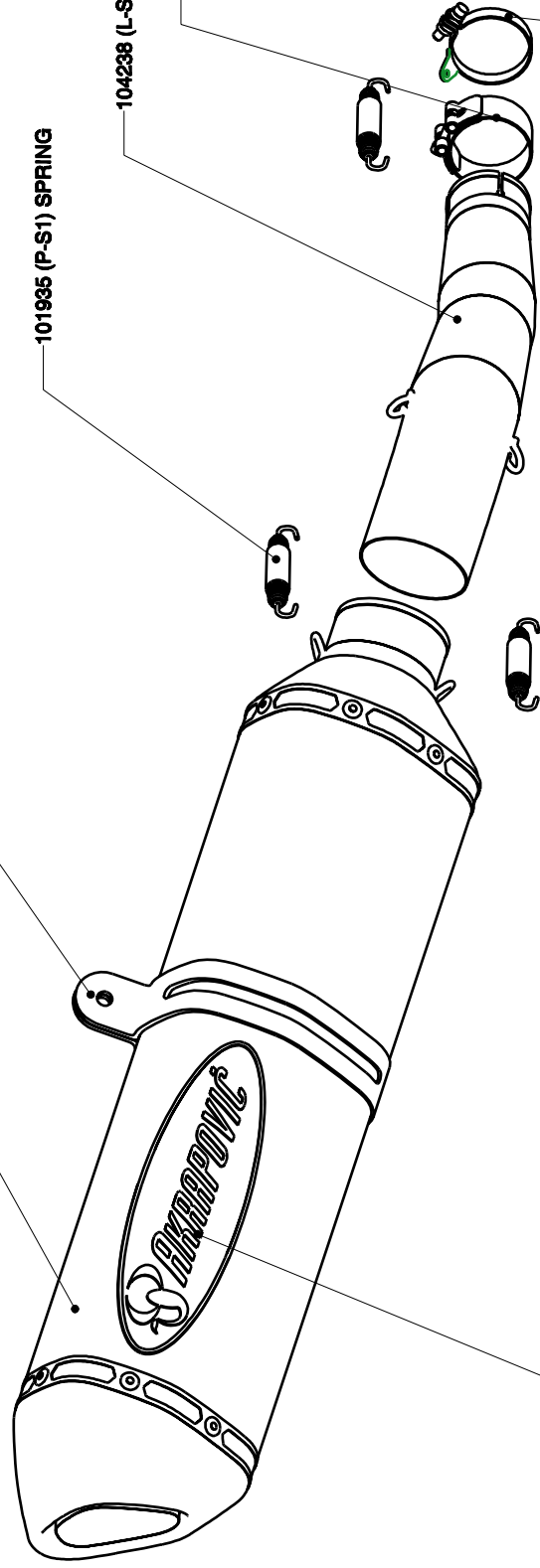

101959 (P-ST1A) STICKER

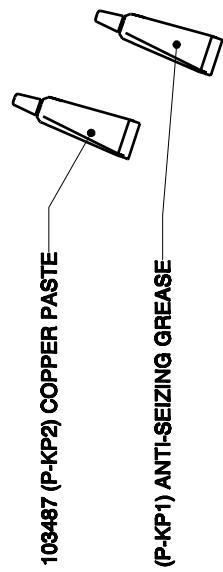

103487 (P-KP2) COPPER PASTE

101976 (P-KP1) ANTI-SEIZING GREASE

SUZUKI GSX-R 1000 Slip-on system with SS link pipe, street legal, model year: 2005-2006

**Product code: 105540 (S-S10SO2-HZT) Titanium outer sleeve muffler
105541 (S-S10SO2-HZC) Carbon fibre outer sleeve muffler**

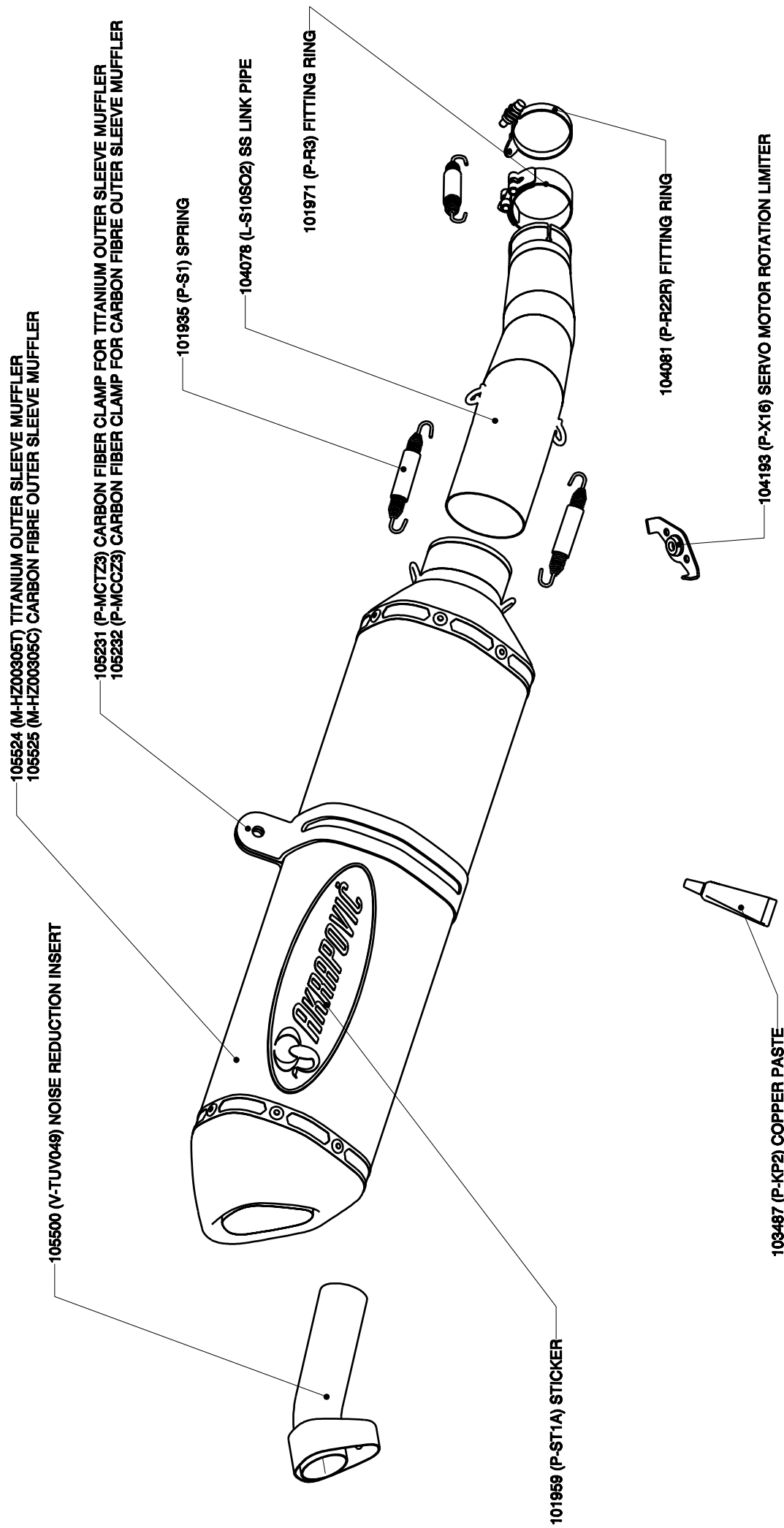

SUZUKI GSX-R 1000 Slip-on system with titanium link pipe, street legal, model year: 2005-2006

**Product code: 105542 (S-S10SO2T-HZT) Titanium outer sleeve muffler
105543 (S-S10SO2T-HZC) Carbon fibre outer sleeve muffler**

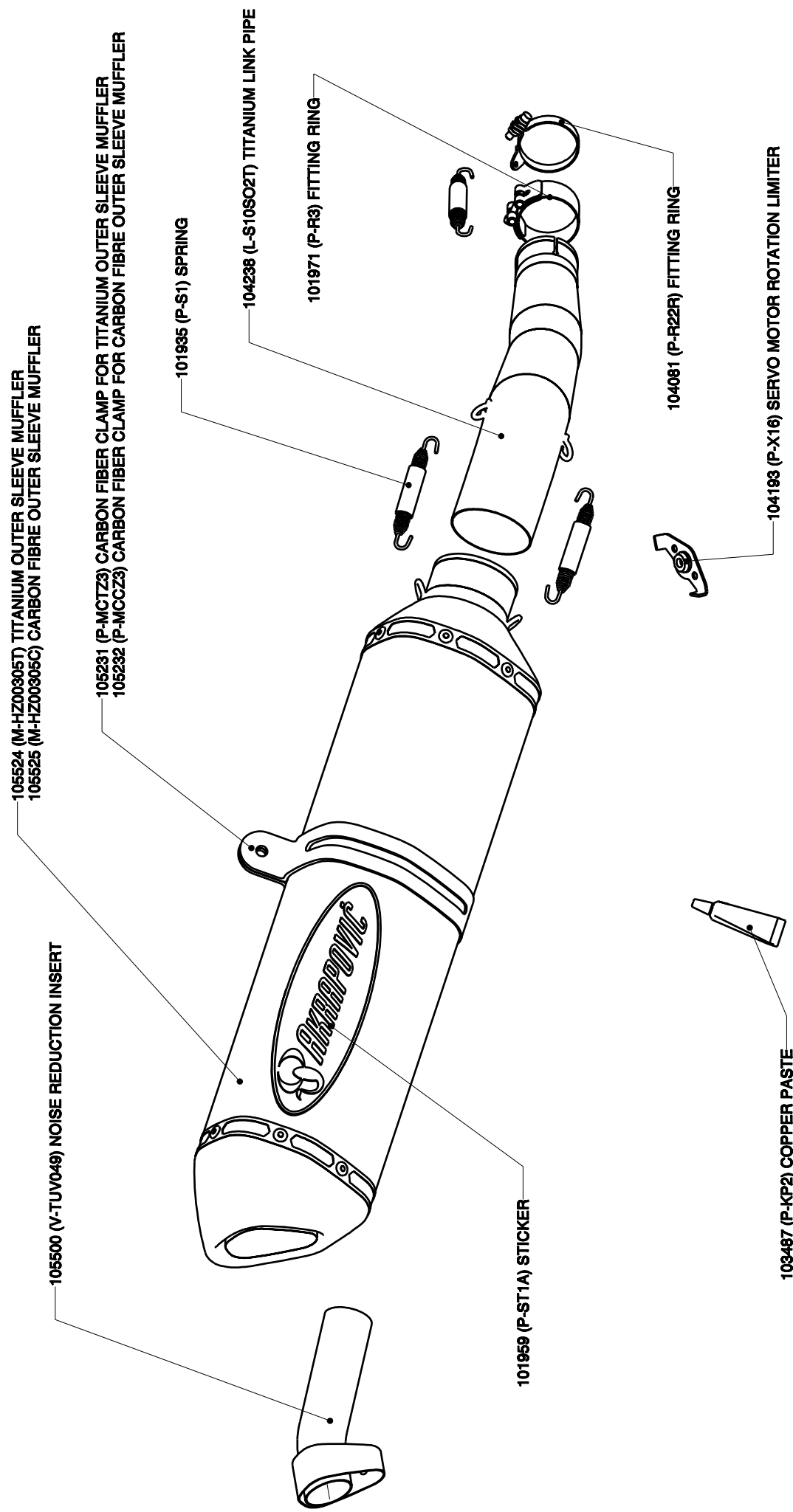

WARNING:

Please note that certain aftermarket exhaust systems may not comply with applicable California laws and regulations, and may therefore be prohibited for use on California highways or roads, or on roads or vehicles otherwise subject to emissions control requirements.

Akrapovič exhaust systems for automobiles and motorcycles mounted downstream of the catalytic converter (also known as “cat-back systems”) are considered “replacement parts” in California by the California Air Resources Board (CARB), and do not require an exemption or executive order from CARB to be sold in California. However, California prohibits the use of any aftermarket exhaust system that modifies, removes or replaces original equipment catalysts, unless CARB has issued an Executive Order as to such part or system.

Further, Akrapovič parts or exhaust systems used or intended for use on “racing vehicles” (i.e. a competition vehicle used exclusively for competition on closed-course circuits) do not require an exemption or Executive Order from CARB to be sold in California. However, such parts are prohibited from use on California public highways or roads, even if occasionally used “off-road.”